



---

parweld

XTM503Si

OPERATOR MANUAL

ISSUE 3



## **Welcome**

Thank you and congratulations on choosing Parweld. This Owner's Manual is designed to help you get the most out of your Parweld products. Please take time to read the Safety precautions. They will help you protect yourself against potential hazards in the workplace. With proper maintenance this equipment should provide years of reliable service. All our systems conform to ISO9001: 2000 and are independently audited by NQA.

The entire product range carries the CE mark, and is constructed in accordance with European directives and the product specific standards where they apply.

## **Further Information**

Parweld is the UK's leading supplier of MIG, TIG and Plasma torches and consumables.

For more information about Parweld's complete range visit: [www.parweld.com](http://www.parweld.com)



## Contents

	Page
<b>1.0 Safety Precautions</b>	<b>4</b>
<b>2.0 Product Description</b>	<b>5</b>
<b>3.0 Technical Specifications</b>	<b>6</b>
<b>4.0 Description of Controls</b>	<b>6</b>
4.1 Setting/ Calibration Menu	7
<b>5.0 Installation</b>	<b>7</b>
5.1 Unpacking the Machine	7
5.2 Location	7
5.3 Input and Grounding Connection	7
5.4 Output Polarity Connections	7
5.5 Changing Drive Roll Sets	7
5.6 Welding Wire Installation	8
5.7 Torch Installation	8
5.8 Work Return Lead Connection	9
5.9 Shielding Gas Connection	9
<b>6.0 Operation</b>	<b>9</b>
6.1 MIG Welding Feeding Wire Electrode	9
6.2 MMA Welding	10-11
<b>7.0 Fault Finding</b>	<b>11-13</b>
<b>8.0 Accessories</b>	<b>13</b>
8.1 Gas Equipment	13
<b>9.0 EC Declaration of Conformity</b>	<b>14</b>
9.1 RoHS Compliance Declaration	14
9.2 WEEE Statement	15
9.3 Statement of Warranty	15

## 1.0 Safety Precautions

### **ELECTRIC SHOCK can kill.**

Touching live electrical parts can cause fatal shocks or severe burns. The electrode and work circuit is electrically live whenever the output is on. The input power circuit and machine internal circuits are also live when power is on. In semiautomatic or automatic wire welding, the wire, wire reel, drive roll housing, and all metal parts touching the welding wire are electrically live. Incorrectly installed or improperly grounded equipment is a hazard.

Do not touch live electrical parts.

Wear dry, sound insulating gloves and body protection.

Insulate yourself from work and ground using dry insulating mats or covers big enough to prevent any physical contact with the work ground.

Additional safety precautions are required when any of the following electrically hazardous conditions are present: in damp locations or while wearing wet clothing; on metal structures such as floors, gratings, or scaffolds; when in cramped positions such as sitting, kneeling, or lying; or when there is a high risk of unavoidable or accidental contact with the work piece or ground. For these conditions, use the following equipment in order presented: 1) a semiautomatic DC constant voltage (wire) welder, 2) a DC manual (stick) welder, And, do not work alone!

Disconnect input power before installing or servicing this equipment. Lockout/tagout input power according to Safety Standards.

Properly install and ground this equipment according to national and local standards.

Always verify the supply ground - check and ensure that input power cable ground wire is properly connected to ground terminal in the receptacle outlet.

When making input connections, attach proper grounding conductor first - double-check connections.

Frequently inspect input power cable for damage or bare wiring - replace cable immediately if damaged - bare wiring can kill.

Turn off all equipment when not in use.

Do not use worn, damaged, under sized, or poorly spliced cables.

Do not drape cables over your body.

If earth grounding of the work piece is required, ground it directly with a separate cable.

Do not touch electrode if you are in contact with the work, ground, or another electrode from a different machine.

Use only well-maintained equipment. Repair or replace damaged parts at once. Maintain unit according to manual.

Wear a safety harness if working above floor level.

Keep all panels and covers securely in place.

Clamp work cable with good metal-to-metal contact to work piece or worktable as near the weld as practical.

Insulate work clamp when not connected to work piece to prevent contact with any metal object.

Welding produces fumes and gases. Breathing these fumes and gases can be hazardous to your health.

### **FUMES AND GASES can be hazardous.**

Keep your head out of the fumes. Do not breathe the fumes.

If inside, ventilate the area and/or use local forced ventilation at the arc to remove welding fumes and gases.

If ventilation is poor, wear an approved respirator.

Read and understand the Material Safety Data Sheets (MSDS's) and the manufacturer's instructions for metals, consumable, coatings, cleaners, and de-greasers.

Work in a confined space only if it is well ventilated, or while wearing an air-supplied respirator. Always have a trained watch person nearby. Welding fumes and gases can displace air and lower the oxygen level causing injury or death. Be sure the breathing air is safe.

Do not weld in locations near de-greasing, cleaning, or spraying operations. The heat and rays of the arc can react with vapours to form highly toxic and irritating gases.

Do not weld on coated metals, such as galvanized, lead, or cadmium plated steel, unless the coating is removed from the weld area, the area is well ventilated, and while wearing an air-supplied respirator. The coatings and any metals containing these elements can give off toxic fumes if welded.

### **ARC RAYS can burn eyes and skin.**

Arc rays from the welding process produce intense, visible and invisible (ultraviolet and infrared) rays that can burn eyes and skin. Sparks fly off from the weld.

Wear an approved welding helmet fitted with a proper shade of filter lenses to protect your face and eyes when welding or watching

Wear approved safety glasses with side shields under your helmet.

Use protective screens or barriers to protect others from flash, glare and sparks; warn others not to watch the arc.

Wear protective clothing made from durable, flame resistant material (leather, heavy cotton, or wool) and foot protection. Welding on closed containers, such as tanks, drums, or pipes, can cause them to blow up. Sparks can fly off from the welding arc. The flying sparks, hot work piece, and hot equipment can cause fires and burns. Accidental contact of electrode to metal objects can cause sparks, explosion, overheating, or fire. Check and be sure the area is safe before doing any welding.

**WELDING can cause fire or explosion.**

Remove all flammables within 10m of the welding arc. If this is not possible, tightly cover them with approved covers.

Do not weld where flying sparks can strike flammable material.

Protect yourself and others from flying sparks and hot metal.

Be alert that welding sparks and hot materials from welding can easily go through small cracks and openings to adjacent areas.

Watch for fire, and keep a fire extinguisher nearby. Be aware that welding on a ceiling, floor, bulkhead, or partition can cause fire on the hidden side.

Do not weld on closed containers such as tanks, drums, or pipes, unless they are properly prepared according to local regulations

Connect work cable to the work as close to the welding area as practical to prevent welding current from travelling along, possibly unknown paths and causing electric shock, sparks, and fire hazards.

Cut off welding wire at contact tip when not in use.

Wear oil-free protective garments such as leather gloves, heavy shirt, cuff less trousers, high shoes, and a cap. Remove any combustibles, such as a butane lighter or matches, from your person before doing any welding.

**FLYING METAL can injure eyes.**

Welding, chipping, wire brushing, and grinding cause sparks and flying metal. As welds cool they can throw off slag. Wear approved safety glasses with side shields even under your welding helmet.

**BUILDUP OF GAS can injure or kill.**

Shut off shielding gas supply when not in use. Always ventilate confined spaces or use approved air-supplied respirator.

**HOT PARTS can cause severe burns.**

Do not touch hot parts with bare handed.

Allow cooling period before working on gun or torch.

To handle hot parts, use proper tools and/or wear heavy, insulated welding gloves and clothing to prevent burns.

**MAGNETIC FIELDS can affect pacemakers.**

Pacemaker wearers keep away.

Wearers should consult their doctor before going near arc welding, gouging, or spot welding operations.

**NOISE can damage hearing.**

Noise from some processes or equipment can damage hearing.

Wear approved ear protection if noise level is high.

Shielding gas cylinders contain gas under high pressure.

**CYLINDERS can explode if damaged.**

Protect compressed gas cylinders from excessive heat, mechanical shocks, physical damage, slag, open flames, sparks, and arcs. Install cylinders in an upright position by securing to a stationary support or cylinder rack to prevent falling or tipping. Keep cylinders away from any welding or other electrical circuits. Never drape a welding torch over a gas cylinder. Never allow a welding electrode to touch any cylinder. Never weld on a pressurized cylinder - explosion will result. Use only correct shielding gas cylinders, regulators, hoses, and fittings designed for the specific application; maintain them and associated parts in good condition.

Turn face away from valve outlet when opening cylinder valve.

Use the right equipment, correct procedures, and sufficient number of persons to lift and move cylinders.

Read and follow instructions on compressed gas cylinders, associated equipment, and Compressed Gas Association (CGA)

## 2.0 Product Description

The XTM503si is a complete semiautomatic constant voltage DC arc welding machine built to meet CE specifications. It combines a constant voltage power source and a constant speed wire feeder with a microcomputer-based controller to form a reliable high-performance welding system. A simple control scheme, consisting of range voltage and wire feed speed controls, provides versatility with ease of use and accuracy. Other features include wire reel spindle with adjustable brake for 15kg wire spools (300mm), an integral gas cylinder mounting undercarriage, an adjustable Argon flow regulator with cylinder pressure gauge and inlet hose, a Parweld MIG torch, and a 3.0m work cable with clamp.

## 3.0 Technical Specifications

The XTM 503si, Is a compact type machines with integrated wire feed units for use with three phase 400V supply. The machine uses inverter technology to allow MIG , TIG and MMA welding to be performed.

Feature	XTM503Si
Input voltage	400V +/-10%
Hz	50/60
Phases	3
Wire drive	4 roll
Current Draw (A)	41.8
Rated input capacitance KVA	27.5
No-load voltage V	73V
Rated working voltage V	16-39
MIG welding current A	40-500
Fuse Rating (A)	32

## 4.0 Description of Controls

- VOLTAGE DISPLAY INDICATOR:** It will be display Arc-Force preset in MMA, and display voltage preset in MIG/MAG, and display real-voltage when the welder is working.
- POWER INDICATOR:** When the machine is turned on, the power indicator will be on.
- ALARM INDICATOR:** When the thermal indicator is on, it shows the machine is overloaded and the internal temperature is too high. Weld output will turn off automatically but the fan will still be working. When the internal temperature is decreased, the overload light will turn off and the machine will be ready to weld
- OUTPUT INDICATOR:** When illuminated the output power is on.
- CURRENT/WIRE SPEED DISPLAY:** Displays the wire feed speed or the welding current depending upon the feature selected.
- LEFT ADJUST KNOB:** Its main function is adjusting welding current in MMA mode; and the final current setting in 4T mode (crater fill)
- MIDDLE ADJUST KNOB:** Its main function is adjusting Arc-Force in MMA, and adjusting welding voltage in MIG/MAG, for the crater fill.
- RIGHT ADJUST KNOB:** Its main function is adjusting the inductance in MIG welding, low inductance allows the current to surge during dip transfer, high inductance gives stability during spray transfer.
- MIG MODE SELECTOR:** This button toggles between the Manual MIG Welding mode and the synergic MIG welding mode.
- TRIGGER MODE.2T:** Operation is when the trigger is depressed and held in for the duration of the welding cycle. 4T mode allows the trigger to be pressed and released. At the end of the weld pressing the trigger in again and holding activates the Crater fill current until the trigger is released.



- WELD FUNCTION SELECTION BUTTON:** Users can select MMA or MIG/MAG function by this button, and the indicators at the left part of button will indicate the selection weld function.
- MIG/MIG WIRE DIAMETER SELECTION BUTTON:** Users can select wire diameter by this button, and the indicators at the left part of button will indicate the selection wire.(only applies in Synergic mode)
- MIG/MAG GAS SELECTION BUTTON:** Users can select shielding gas by this button. (only applies in Synergic mode)
- GAS PURGE BUTTON:** Purges the shielding gas when depressed.
- REMOTE CONTROL:** For the Welding current (synergic mode) or the wire speed (manual mode)
- REMOTE CONTROL:** For the arc length +/- (synergic mode) or the Arc Voltage (manual mode)
- WIRE LOADING BUTTON:**
- TORCH CONNECTOR:** The Euro connector provided the external connection for the welding torch.



## 4.1 Setting/ Calibration Menu

It is possible to adjust the following parameters to suit operator preference

- Burn back time (adjusts the wire stick out at the end of a weld)
- Post gas time (adjusts the amount of time the gas flows after a weld has finished)
- Calibration of the wire feed speed (Use only during machine calibration)

To enter the setting menu press buttons 12 and 13 at the same time until the left hand display shows FSd, bbt or POG.

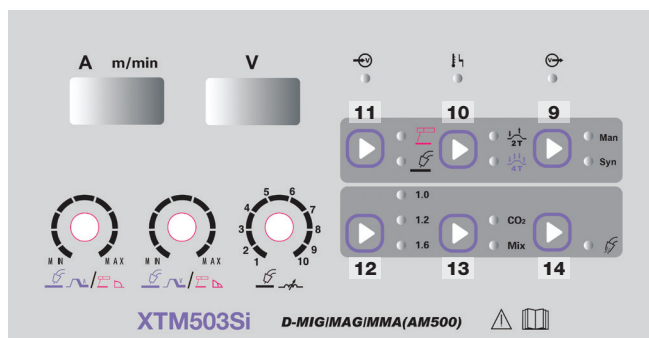

Now press button 12 or 13 to scroll to the desired value to be adjusted

<b>FSd</b>	<b>Calibration of the wire feed speed</b>
<b>bbt</b>	<b>Burn back time</b>
<b>POG</b>	<b>Post gas time</b>

Press button 9 and 10 to increase or decrease the value which is displayed in the right hand screen.

If no buttons are pressed for 2 seconds the machine will exit the setting mode

FSd Calibration for wire feeding speed, setting range: -30~+30. Use this adjustment when the display Amps and real output Amps don't match. When the real output is lower than preset value, increase the FSd setting; vice versa.

bbt(Burn Back Time): Burn back time period calibration, setting range 0~1.5s. Increasing the burn back time will shorten the wire stickout at the end of the weld.

POG(Post Gas): Post gas time period calibration, setting range 0~10s.

## 5.0 Installation

Read entire installation section before starting installation.

### SAFETY PRECAUTIONS

- **ELECTRIC SHOCK can kill.**
- **Only qualified personnel should perform this installation.**
- **Only personnel that have read and understood the Operating Manual should install and operate this equipment.**
- **Machine must be grounded per any national, local or other applicable electrical regulations.**
- **The MIG power switch is to be in the OFF position when installing work cable and torch and when connecting other equipment.**

### 5.1 Unpacking the Machine

Cut banding and lift off cardboard carton. Cut banding holding the machine to the skid. Remove corrugated packing material. Remove accessories from Gas Bottle Platform.. Roll the machine off the skid

### 5.2 Location

Locate the welder in a dry location where there is free circulation of clean air into the louvres in the back and out the front. A location that minimizes the amount of smoke and dirt drawn into the rear louvres reduces the chance of dirt accumulation that can block air passages and cause overheating.

### 5.3 Input and Grounding Connection

#### WARNING

**Before starting the installation, check that your power supply is adequate for the voltage, amperage, phase, and frequency specified on the Machine nameplate.**

The 230 volt 50 Hz machine is supplied with a 4m input cable and without plug, ensure that you connect a plug that is suitably rated for the power draw of the machine and the environmental location.

Using the, have a qualified electrician connect the input plug. For long runs over 30m , larger copper wires should be used. The green/yellow wire in the input cable connects to the frame of the machine. This ensures proper grounding of the machine when the machine plug is inserted into the receptacle.

### 5.4 Output Polarity Connections

MIG, TIG and MMA welding use different electrode polarities. The polarity of the MIG torch can be selected by connection of the torch cable to the + or - socket the front of the welder, (+) polarity. This is the normal polarity for MIG welding with GAS.

### 5.5 Changing Drive Roll Sets

1. Turn off the power source.
2. Release the pressure on the idle rolls by swinging the adjustable pressure arm down. Lift the cast idle roll assembly and allow it to sit in an upright position.
3. Unscrew the plastic knob retaining the lower grooved drive roll and side off the drive roller.
4. Ensure the wire size marked on the side of the feed roller matches the wire size to be used.
5. Replace the drive rolls in reverse of the above procedure ensuring the wire size to be used is marked on the outward facing side of the roller as it is refitted.

**NOTE: Be sure that the torch liner and contact tip are also sized to match the selected wire size.**

## 5.6 Welding Wire Installation

1. Open the Wire drum cover by pulling down and out on the bottom of the cover
2. Unscrew the plastic retaining wheel from the end of the spool holder shaft.
3. Position the wire spool so that it will rotate in a direction when feeding so as to be de-reeled from the bottom of the coil.
4. Slide the wire spool all the way onto the shaft and refit the plastic retaining nut.

**Note:- There is a friction brake on the reel hub assembly to prevent the wire spool over running when welding stops ensure the this is slackened to the minimum setting. It can be adjusted by means of the nut visible when the plastic nut is removed.**

5. Turn the Spool until the free end of the electrode is accessible. While securely holding the electrode, cut off the bent end and straighten the first six inches. (If the electrode is not properly straightened, it may not feed properly through the wire drive system. Manually feed the wire from the wire reel and through the wire guide and then over the top of the wire feed rollers (ensure the pressure arms are in the raised position.)

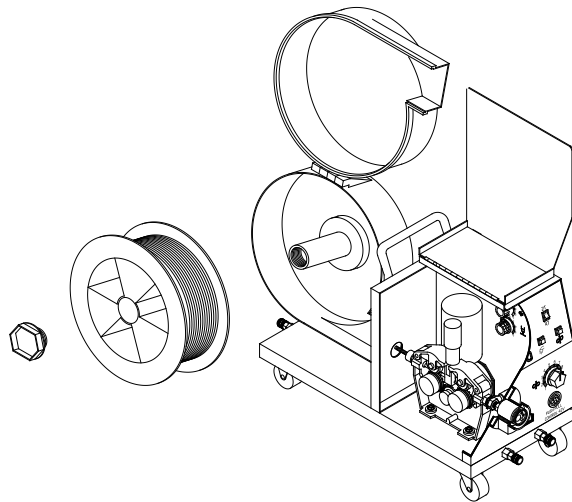

6. Continue to feed the wire through the outlet guide until 20mm of wire is protruding from the front of the machine torch connector.
7. Reposition the adjustable pressure arms to their original position to apply pressure. Adjust pressure as necessary.

**Note the pressure arm should be adjusted in order to give the minimum amount of pressure on the wire to allow reliable feeding,**

## 5.7 Welding Wire Installation

1. Open the Wire Drive Compartment Door by lifting the 2 finger catches on the side panel.
2. Unscrew the plastic retaining wheel from the end of the spool holder shaft.
3. Position the wire spool so that it will rotate in a direction when feeding so as to be de-reeled from the bottom of the coil.
4. Slide the wire spool all the way onto the shaft and refit the plastic retaining nut.

**Note:- there is a friction brake on the reel hub assembly to prevent the wire spool over running when welding stops ensure**

**the this is slackened to the minimum setting. It can be adjusted by means of the nut visible when the plastic nut is removed.**

5. Turn the Spool until the free end of the electrode is accessible. While securely holding the electrode, cut off the bent end and

straighten the first six inches. (If the electrode is not properly straightened, it may not feed properly through the wire drive system. Manually feed the wire from the wire reel and through the wire guide and then over the top of the wire feed roller (ensure the pressure arm is in its raised position.)

6. Continue to feed the wire through the outlet guide until 20mm of wire is protruding from the front of the machine torch connector.
7. Reposition the adjustable pressure arm to its original position to apply pressure. Adjust pressure as necessary.

**Note the pressure arm should be adjusted in order to give the minimum amount of pressure on the wire to allow reliable feeding,**

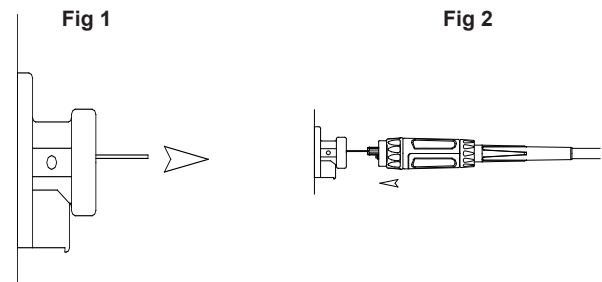

## 5.7 Torch Installation

Your Parweld MIG/MAG Welding Torch has been supplied ready to

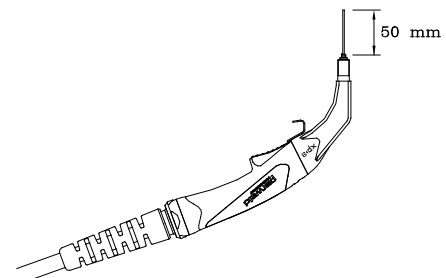

weld. It has been supplied with the standard consumables denoted in the product brochure.

To connect the torch to the power source:-

1. Remove the tip adaptor and contact tip
2. Inch the wire from the exit of the wire guide on the feed unit as Figure 1. Ensure that it does not short out on any machine panels.
3. Carefully slide the electrode wire into the torch liner and slowly locate the torch gun plug body into the feed unit central connector and tighten the gun plug nut as Figure 2



**Note; To aid the initial location of a new torch and to prevent damage to the gas nipple O-ring a very light application of grease to the O Ring is beneficial.**

4. Keeping the torch as straight as possible, use the power source inch facility or torch trigger to feed the electrode wire 50mm from the end of the liner conduit.
5. Once the electrode wire has stopped, refit the tip adaptor, diffuser, contact tip and gas nozzle.
6. Trim the electrode wire to within 5mm of the face of the nozzle, this will facilitate jolt free arc initiation.
7. Press the gas purge button and check the gas flow is adequate for your application.
8. An inexpensive flow meter is available from Parweld reference 806001.
9. If you are setting a water-cooled torch ensure you have the recommended water flow rate.

**Note;- It is essential to ensure adequate flow of clean, cool water to prevent irreparable torch failure, a minimum of 1.2 l/ min is recommended.**

Parweld recommend the use of its XTS water recirculation system designed specifically for use with all water cooled MIG, TIG and Plasma welding torches.

The Parweld XTS recirculation equipment can be fitted with a fail-safe flow protection device to prevent overheating or meltdown.

Note. Water flows into the torch through the blue hose. The blue hose delivers cold water directly to the prime source of heat, the swan neck and consumable. The re circulated water is then passed through the torch power cable to cool the power cable as it is returned to the cooler through the red water return lead.

Ensure all air is removed from the water cooling circuit before welding.

## 5.8 Work Return Lead Connection

Insert the work return lead connector into the receptacle on the front panel of the machine and twist it clockwise until tightly secured.

Connect the earth clamp to the work piece as close as possible to the point to be welded and ensure that a good electrical connection is created to bare metal.

## 5.9 Shielding Gas Connection

1. Using the gas hose supplied connect the hose to the gas inlet connection on the rear of the machine and tighten it with a spanner.
2. Connect the opposite end of the gas hose to the output connection of a gas regulator capable of supplying the correct gas flow for the welding operation.

**Note if the gas cylinder is to be stored on the back of the machine ensure it is secured using the retention chain provided**

## 6.0 Operation

1. Switch on the machine using the mains on/off switch, This lights the Green LED above the voltage selector switch.
2. Select the welding mode using push button (13) and switching option with Button (14)

### 6.1 MIG Welding Feeding Wire Electrode

You can MIG weld in 2 modes Manual and Synergic the manual mode takes more skill to setup.

#### Synergic MIG, (Carbon steels only)

Select the Synergic MIG mode using button (9)

Select the Gas type using button (13)

Select the wire diameter using button (12)

Rotate the amperage button (15) on the wire feeder to select the desired welding amperage. The machine will adjust the welding voltage automatically but you may trim the arc length using the Voltage knob on the feeder to increase or decrease the arc length which will be displayed on the V display, and the inductance to your personal preference by adjustment of the Voltage knob (16) and inductance (8) The voltage will increase or decrease penetration and the inductance affects the arc stability and droplet transfer.

#### Manual MIG

Select the Manual MIG mode using button (9)

Select the desired welding voltage using the knob (16)

Select the desired welding amperage (wire speed) using the knob (15). Note I manual mode the Amperage display shows wire speed m/min when adjusting. You should then adjust the machine settings until they are in balance with each other giving a smooth stable arc.

#### 4T Operation.

Operation in the 4T trigger mode gives the advantage of the option of a crater fill current, at the end of the weld. Select 4T mode using button (10). Using the control knobs on the front panel of the machine in synergic mode you can select the final current (6) and trim the arc length with knob (7). If you are working in manual mode then the parameter are arc voltage and wire speed.

You will note in this mode the main welding parameter are set on the wire feeder and the crater fill parameters are set on the power source and the display changes to display whatever is the currently adjusted parameter.

In operation press and release the trigger to start and when you reach the end of the weld, press and hold the trigger in which will activate the crater fill settings until you release the trigger which stops the welding process.

**Note: Check that drive rolls, and torch parts are correct for the wire size and type being used.**

3. The optimum idle roll pressure varies with type of wire, wire diameter, surface conditions, lubrication, and hardness. As a general rule, hard wires may require greater pressure, and soft, or aluminium wire, may require less pressure than the factory setting. The optimum idle roll setting can be determined as follows:
4. Press end of gun against a solid object that is electrically isolated from the welder output and press the gun trigger for several seconds.
5. If the wire "bird nests", jams or breaks at the drive roll, the idle roll pressure is too great. Back the adjustment knob out 1/2 turn, run new wire. If the only result was drive roll slippage, loosen the Hand nut on the central connector and pull the gun forward about 6" (15cm) away from the power source. There should be a slight waviness in the exposed wire. If there is not waviness, the pressure is too low. Tighten the adjustment knob 1/4 turn, reinstall the gun cable and repeat the above steps.
1. When triggering, the electrode and drive mechanism are electrically "LIVE" relative to work and ground and remain "LIVE" several seconds after the gun trigger is released.

**WARNING**

**When using an open arc process, it is necessary to use correct eye, head, and body protection.**

2. Position wire over joint. The end of the wire may be lightly touching the work.
3. Lower welding helmet, operate gun trigger, and begin welding. Hold the gun so the contact tip to work distance is about 3/8" (10 mm).
4. To stop welding, release the gun trigger and then pull the gun away from the work after the arc goes out.
5. When no more welding is to be done, close valve on gas cylinder (if used), momentarily operate gun trigger to release gas pressure and turn off the machine.

**NOTE These settings are guidelines only. Material and wire type, joint design, fit up, position, shielding gas, etc. affect settings. Produce test welds to be sure they comply to specifications.**

**Material thickness determines weld parameters.**

1. Convert Material Thickness to Amperage (A) (0.25mm= 1 Amp)  
3.2mm = 125 A
  2. Select Wire Size
- | Amperage Range | Wire Size |
|----------------|-----------|
| 40 - 145 A     | 0.8 mm    |
| 50 - 180 A     | 1.0 mm    |
| 75 - 250 A     | 1.2 mm    |

3. Select Wire Speed (Amperage)

Wire Size	Feed speed
0.8 mm	0.05m/min per Amp
1.0 mm	0.04m/min per Amp
1.2 mm	0.025m/min per Amp

So based on 3.2 mm material thickness amperage should be 125A if using 1.0mm wire then the wire feed speed should be 0.04 X 125= 5m/min

Wire speed (amperage) controls weld penetration

4. Select Voltage. Voltage controls height and width of weld bead.

Low Voltage: wire stubs into work

High Voltage: arc is unstable (spatter)

Set voltage midway between high/low voltages.

And then fine tune accordingly

## 6.2 MMA Welding

### Output Polarity Connections

Electrode polarity

MMA electrodes are generally connected to the '+' terminal and the work lead to the '-' terminal

But if in doubt consult the electrode manufacturer's literature.

### MMA Welding Operation

**WARNING**

**When using an open arc process, it is necessary to use correct eye, head, and body protection.**

### MMA Welding Guide

Using the selector button 13 toggle through the functions until the MMA light is illuminated

You can adjust the welding amperage using the knob (5) and the arc force using the knob (7)

Effects of MMA welding various materials

High tensile and alloy steels

The two most prominent effects of welding these steels are the formation of a hardened zone in the weld area, and, if suitable precautions are not taken, the occurrence in this zone of under-bead cracks. Hardened zone and under-bead cracks in the weld area may be reduced by using the correct electrodes, preheating, using higher current settings, using larger electrode sizes, short runs for larger electrode deposits or tempering in a furnace.

**Manganese Steels**

The effect on manganese steel of slow cooling from high temperatures is embrittlement. For this reason it is absolutely essential to keep manganese steel cool during welding by quenching after each weld or skip welding to distribute the heat.

**Cast Iron**

Most types of cast iron, except white iron, are weldable. White iron, because of its extreme brittleness, generally cracks when attempts are made to weld it. Trouble may also be experienced when welding white-heart malleable, due to the porosity caused by gas held in this type of iron.

**Copper and Alloys**

The most important factor is the high rate of heat conductivity of copper, making preheating of heavy sections necessary to give proper fusion of weld and base metal.

**Types of Electrodes**

Arc welding electrodes are classified into a number of groups depending on their applications. There are a great number of electrodes used for specialized industrial purposes which are not of particular interest for everyday general work. These include some low hydrogen types for high tensile steel, cellulose types for welding large diameter pipes, etc. The range of electrodes dealt with in this publication will cover the vast majority of applications likely to be encountered; are all easy to use and all will work on even the most basic of welding machines.

**Metals Being Joined & Electrode Comments**

**Mild Steel**

6013 ideal electrodes for all general purpose work. Features include outstanding operator appeal, easy arc starting and low spatter.

**Mild Steel**

7014 all positional electrode for use on mild and galvanized steel furniture, plates, fences, gates, pipes and tanks etc. Especially suitable for vertical down welding.

**Cast Iron**

99% nickel suitable for joining all cast irons except white cast iron

**Stainless Steel**

318L-16 high corrosion resistance. Ideal for dairy work, etc. On stainless steels vertical, lift the torch up from the work piece to draw out an arc. To prevent melting of the end of the tungsten so this in a smooth rapid movement

TIG welding guide ranges.

## 7.0 Fault Finding

Problem	Cause/Corrective Action
<p>Porosity - small cavities or holes Resulting from gas pockets in weld metal.</p>	<p>Inadequate shielding gas coverage. Check for proper gas flow rate.</p> <p>Remove spatter from gun nozzle. Check gas hoses for leaks. Eliminate drafts near welding arc. Place nozzle 6-13 mm from work piece Hold gun near bead at end of weld until molten metal solidifies.</p> <p>Wrong gas. Use welding grade shielding gas; change to different gas.</p> <p>Dirty welding wire. Use clean, dry welding wire. Eliminate pickup of oil or lubricant on welding wire from feeder or liner.</p> <p>Work piece dirty. Remove all grease, oil, moisture, rust, paint, coatings, and dirt from work surface before welding. Use a more highly deoxidizing welding wire (contact supplier).</p> <p>Welding wire extends too far out of nozzle. Be sure welding wire extends not more than 13 mm beyond nozzle.</p>

Problem	Cause/Corrective Action
Incomplete fusion to base metal	<p>Work piece dirty. Remove all grease, oil, moisture, rust, paint, coatings, and dirt from work surface before welding.</p> <p>Insufficient heat input. Select higher voltage range and/or adjust wire feed speed.</p> <p>Improper welding technique. Place stringer bead in proper locations) at joint during welding.</p> <p>Adjust work angle or widen groove to access bottom during welding.</p> <p>Momentarily hold arc on groove side walls when using weaving technique.</p> <p>Keep arc on leading edge of weld puddle. Use correct gun angle of 0 to 15 degrees.</p>
Excessive Penetration – weld metal melting through base metal and hanging underneath weld.	<p>Excessive heat input. Select lower voltage range and reduce wire feed speed.</p> <p>Increase travel speed.</p>
Lack Of Penetration - shallow Fusion between weld metal and Base metal.	<p>Improper joint preparation. Material too thick. Joint preparation and design must provide access to bottom of groove while maintaining Proper welding wire extension and arc characteristics.</p> <p>Improper weld technique. Maintain normal gun angle of 0 to 15 degrees to achieve maximum penetration. Keep arc on leading edge of weld puddle. Ensure welding wire extends not more than 13 mm beyond nozzle.</p> <p>Insufficient heat input. Select higher wire feed speed and/or select higher voltage range.</p> <p>Reduce travel speed.</p>
Burn-Through - weld metal melting Completely through base metal Resulting in holes where no metal remains.	<p>Excessive heat input. Select lower voltage range and reduce wire feed speed.</p> <p>Increase and/or maintain steady travel speed.</p>

Problem	Cause/Corrective Action
Excessive Spatter - scattering of Molten metal particles that cool to solid form near weld bead.	<p>Wire feed speed too high. Select lower wire feed speed.</p> <p>Voltage too high. Select lower voltage range.</p> <p>Electrode extension (stick out) too long. Use shorter electrode extension (stick out).</p> <p>Work piece dirty. Remove all grease, oil, moisture, rust, paint, undercoating, and dirt from work surface before welding.</p> <p>Insufficient shielding gas at welding arc. Increase flow of shielding gas at regulator/flow meter and/or prevent drafts near welding arc.</p> <p>Dirty welding wire. Use clean, dry welding wire. Eliminate pickup of oil or lubricant on welding wire from feeder or liner.</p>
Wire feed unit operates but no gas flow .	<p>Gas cylinder empty</p> <p>Gas regulator closed</p> <p>Faulty solenoid</p> <p>Restriction in torch cables</p>
Wire feed unit operates, but does not feed	<p>Insufficient drive roll pressure</p> <p>Incorrect drive rolls</p> <p>Excessive wire spool brake tension</p> <p>Incorrect liner</p> <p>Blocked liner</p> <p>Bird nesting</p> <p>Burn back</p>
Bird nesting	<p>Excessive feed roll pressure</p> <p>Incorrect or blocked liner</p> <p>Incorrect contact tip size</p> <p>Contact tip overheating</p> <p>Restriction in torch cable</p> <p>Misaligned drive rolls or wire guides</p> <p>Excessive cable kinkage</p>
Burn back	<p>Improper voltage setting</p> <p>Improper stick out</p> <p>Erratic wire feed</p> <p>Incorrect or blocked liner</p> <p>Contact tip overheating</p> <p>Excessive cable kinking</p>

Problem	Cause/Corrective Action
Erratic Wire Feeding or Arc	Improper drive roll tension Improper drive roll size Worn drive rolls Incorrect or blocked liner Incorrect wire guide size Misaligned drive rolls or wire guide Gaps at liner or wire guide junctions Incorrect contact tip size Contact Tip overheating Spatter adhesion on exit geometry of tip bore Excessive cable kinkage Poor earth or cable connections Weld joint area dirty
Yellow temperature light illuminates	Power source has over heated leave the machine running to allow it to cool down. Ensure entry and exit vents on machine are clear and machine has a good supply of cooling air. Reduce operating duty cycle and or amperage.

## 8.0 Accessories

### 8.1 Gas Equipment

#### Everyday Gas Regulators – 300 BAR Single Stage

##### Features

Flow rate up to 96m<sup>3</sup>/h (3389 ft<sup>3</sup>/h)

- Full 300 bar capability
- Outlet pressure indicated on the bonnet
- Bottom entry design suited for top outlet cylinder valves

##### Fittings

- Fitted with standard 3/89 BSP outlet
- Fitted with 5/89 BSP inlet connections



Stock Code	Description	Maximum Outlet Pressure
------------	-------------	-------------------------

E700140	Argon Preset Regulator	3.0
---------	------------------------	-----

##### Bar

E700141	Argon Indicator Regulator	3.0 Bar
---------	---------------------------	---------

E700113	1 Gauge Argon	30 lpm flow
---------	---------------	-------------

E700123	2 Gauge Argon	30 lpm flow
---------	---------------	-------------

### Flow Meters

##### Features

- Designed from brass bar whilst the tube and cover are moulded from high quality polycarbonate to ensure high impact resistance and clarity
- Calibrated to operate at an inlet pressure of 30PSI
- Sensitive needle valve provides easy adjustment and the downward facing outlet connection eliminates hose kinking.



##### Fittings

- Fitted with standard 3/89 BSP inlet and outlet connections

Stock Code	Description
------------	-------------

706101	Flow Meter Mixed Gas 25 lpm (MIG)
--------	-----------------------------------

### Gas flow Tester

- Designed to check gas flow at the front of Mig Torches.

Stock Code	Description
------------	-------------

806001	Gas flow Tester
--------	-----------------



## 9.0 EC Declaration of Conformity

Hereby we declare that the machines as stated below

Type: XTM503Si

Conform to the EC Directives:

Low Voltage Directive 2006/95/EC

EMC Directive 2004/108/EC

Harmonised European standard: EN/IEC 60974-1

This is to certify that the tested sample is in conformity with all provisions of the above detailed EU directives and product standards.



## 9.1 Rohs Compliance Declaration

Directive 2011/65/EU of the European Parliament

Restriction of use of certain hazardous substances in electrical and electronic equipment

Type: XTM503Si

The above listed products are certified to be compliant with the rohs directive with all homogeneous component parts being controlled to ensure material contents as per the list below.

Cadmium 0.01% by weight

Lead 0.1% by weight

Mercury 0.1% by weight

Hexavalent chromium 0.1% by weight

Polybrominated biphenyl's (pbbs) 0.1% by weight

Polybrominated diphenyl ethers (pbdes) 0.1% by weight

It should be noted that under specific exempted applications, where lead is used as an alloying element the following limits are applied in accordance with the regulations.

Copper and copper alloy parts use less than 4% by weight of each homogeneous component.

Steel and steel alloy parts use less than 4% by weight of each homogeneous component.

Aluminium and aluminium alloy parts use less than 4% by weight of each homogeneous component.

Only dispose off in authorised sites for electrical and electronic waste do not dispose of with general refuse or landfill waste.



## 9.2 WEEE Statement

WEEE (Waste Electrical & Electronic Equipment) 2002/96/EC

In relation to implementing the legislation, Parweld has established relevant recycling and recovery methods. We have been fully compliant against the marking requirements since August 2005. Parweld is registered in the UK with the Environment agency as detailed below. For WEE compliance outside the UK please contact your supplier/Importer

Parweld is registered with a compliance scheme Official registration number is WEE/FD0255QV

When your equipment reaches the end of its service life you should return it to Parweld where it will be reconditioned or processed for recycling.

## 9.3 Statement of Warranty

Limited Warranty:

Parweld Ltd, hereafter, "Parweld" warrants its customers that its products will be free of defects in workmanship or material. Should any failure to conform to this warranty appear within the time period applicable to the Parweld products as stated below, Parweld shall, upon notification thereof and substantiation that the product has been stored, installed, operated, and maintained in accordance with Parweld's specifications, instructions, recommendations and recognized standard industry practice, and not subject to misuse, repair, neglect, alteration, or accident, correct such defects by suitable repair or replacement, at Parweld's sole option, of any components or parts of the product determined by Parweld to be defective.

Parweld makes no other warranty, express or implied. This warranty is exclusive and in lieu of all others, including, but not limited to any warranty of merchantability or fitness for any particular purpose.

Limitation of Liability:

Parweld shall not under any circumstances be liable for special, indirect or consequential damages, such as, but not limited to, lost profits and business interruption. The remedies of the purchaser set forth herein are exclusive and the liability of Parweld with respect to any contract, or anything done in connection therewith such as the performance or breach thereof, or from the manufacture, sale, delivery, resale, or use of any goods covered by or furnished by Parweld whether arising out of contract, negligence, strict tort, or under any warranty, or otherwise, shall not, except as expressly provided herein, exceed the price of the goods upon which such liability is based. No employee, agent, or representative of Parweld is authorized to change this warranty in any way or grant any other warranty.

Purchaser's rights under this warranty are void if replacement parts or accessories are used which in Parweld's sole judgement may impair the safety or performance of any Parweld product.

Purchaser's rights under this warranty are void if the product is sold to purchaser by non-authorized persons.

The warranty is effective for the time stated below beginning on the date that the authorized Distributor delivers the products to the purchaser. Notwithstanding the foregoing, in no event shall the warranty period extend more than the time stated plus one month from the date Parweld delivered the product to the authorized distributor.

Main Transformers and Rectifiers 2 Years

Other machine parts 2 year

---

Parweld Limited  
Bewdley Business Park  
Long Bank  
Bewdley  
Worcestershire  
England  
DY12 2TZ

tel. +44 1299 266800  
fax. +44 1299 266900

[www.parweld.com](http://www.parweld.com)  
[info@parweld.co.uk](mailto:info@parweld.co.uk)