



XTP-40

OPERATOR MANUAL

ISSUE 1

Welcome

Thank you and congratulations on choosing Parweld. This Owner's Manual is designed to help you get the most out of your Parweld products. Please take time to read the Safety precautions. They will help you protect yourself against potential hazards in the workplace. With proper maintenance this equipment should provide years of reliable service. All our systems conform to ISO9001: 2008 and are independently audited by NQA.

The entire product range carries the CE mark, and is constructed in accordance with European directives and the product specific standards where they apply.

Further Information

Parweld is the UK's leading manufacturer of MIG, TIG and Plasma torches and consumables. For more information about Parweld's complete range visit: www.parweld.com

Contents



	Page
1.0 Safety Precautions	4
2.0 Product description	5
3.0 Technical Specifications	5
4.0 Description of controls	6
5.0 Installation	6
5.1 Unpacking the Machine	6
5.2 Location	6
5.3 Input and grounding connection	6
5.4 Torch Installation	7
5.5 Work return lead connection	7
6.0 Operation	7
6.1 Consumable parts	7
6.2 switching on the machine	7
6.3 Setting the Air pressure	7
6.4 Getting ready to Cut	7
6.5 Cut quality	8
6.6 Piercing	8
6.7 Operating the Torch	8
7.0 Fault finding	8
8.0 Accessories	10
8.1 Torch spares	10
9.0 EC declaration of conformity	11
9.1 RoHS Compliance Declaration	11
9.2 WEEE Statement	12
9.3 Statement of warranty	12

1.0 Safety Precautions

ELECTRIC SHOCK can kill.

Touching live electrical parts can cause fatal shocks or severe burns. The electrode and work circuit is electrically live whenever the output is on. The input power circuit and machine internal circuits are also live when power is on.

Do not touch live electrical parts.

Wear dry, sound insulating gloves and body protection.

Insulate yourself from work and ground using dry insulating mats or covers big enough to prevent any physical contact with the work ground.

Additional safety precautions are required when any of the following electrically hazardous conditions are present: in damp locations or while wearing wet clothing; on metal structures such as floors, gratings, or scaffolds; when in cramped positions such as sitting, kneeling, or lying; or when there is a high risk of unavoidable or accidental contact with the work piece or ground.

Disconnect input power before installing or servicing this equipment. Lockout/tagout input power according to Safety Standards.

Properly install and ground this equipment according to national and local standards.

Always verify the supply ground - check and ensure that input power cable ground wire is properly connected to ground terminal in the receptacle outlet.

When making input connections, attach proper grounding conductor first - double-check connections.

Frequently inspect input power cable for damage or bare wiring - replace cable immediately if damaged - bare wiring can kill.

Turn off all equipment when not in use.

Do not use worn, damaged, under sized, or poorly spliced cables.

Do not drape cables over your body.

If earth grounding of the work piece is required, ground it directly with a separate cable.

Do not touch torch tip while machine is switched on.

Use only well-maintained equipment. Repair or replace damaged parts at once. Maintain unit according to manual.

Wear a safety harness if working above floor level.

Keep all panels and covers securely in place.

Clamp work cable with good metal-to-metal contact to work piece or worktable as near the weld as practical.

Insulate work clamp when not connected to work piece to prevent contact with any metal object.

Cutting produces fumes and gases. Breathing these fumes and gases can be hazardous to your health.

FUMES AND GASES can be hazardous.

Keep your head out of the fumes. Do not breathe the fumes. If inside, ventilate the area and/or use local forced ventilation at the arc to remove welding fumes and gases.

If ventilation is poor, wear an approved respirator.

Read and understand the Material Safety Data Sheets (MSDS's) and the manufacturer's instructions for metals, consumable, coatings, cleaners, and de-greasers.

Work in a confined space only if it is well ventilated, or while wearing an air-supplied respirator. Always have a trained watch person nearby. Cutting fumes and gases can displace air and lower the oxygen level causing injury or death. Be sure the breathing air is safe.

Do not cut in locations near de-greasing, cleaning, or spraying operations. The heat and rays of the arc can react with vapours to form highly toxic and irritating gases.

Do not cut on coated metals, such as galvanized, lead, or cadmium plated steel, unless the coating is removed from the cut area, the area is well ventilated, and while wearing an air-supplied respirator. The coatings and any metals containing these elements can give off toxic fumes if cut.

ARC RAYS can burn eyes and skin.

Arc rays from the cutting process produce intense, visible and invisible (ultraviolet and infrared) rays that can burn eyes and skin. Sparks fly off from the weld.

Wear an approved welding helmet fitted with a proper shade of filter lens to protect your face and eyes when welding or watching

Wear approved safety glasses with side shields under your helmet.

Use protective screens or barriers to protect others from flash, glare and sparks; warn others not to watch the arc.

Wear protective clothing made from durable, flame resistant material (leather, heavy cotton, or wool) and foot protection. Cutting on closed containers, such as tanks, drums, or pipes, can cause them to blow up. Sparks can fly off from the cutting arc. The flying sparks, hot work piece, and hot equipment can cause fires and burns. Accidental contact of electrode to metal objects can cause sparks, explosion, overheating, or fire. Check and be sure the area is safe before doing any cutting.

WELDING can cause fire or explosion.

Remove all flammables within 10m of the welding arc. If this is not possible, tightly cover them with approved covers.

Do not weld where flying sparks can strike flammable material.

Protect yourself and others from flying sparks and hot metal.

Be alert that welding sparks and hot materials from welding can easily go through small cracks and openings to adjacent areas.

Watch for fire, and keep a fire extinguisher nearby. Be aware that

cutting on a ceiling, floor, bulkhead, or partition can cause fire on the hidden side.

Do not cut on closed containers such as tanks, drums, or pipes, unless they are properly prepared according to local regulations

Connect work cable to the work as close to the welding area as practical to prevent cutting current from travelling along, possibly unknown paths and causing electric shock, sparks, and fire hazards.

Wear oil-free protective garments such as leather gloves, heavy shirt, cuffless trousers, high shoes, and a cap. Remove any combustibles, such as a butane lighter or matches, from your person before doing any cutting.

FLYING METAL can injure eyes.

Cutting, chipping, wire brushing, and grinding cause sparks and flying metal. As cuts cool they can throw off slag. Wear approved safety glasses with side shields even under your welding helmet.

BUILDUP OF GAS can injure or kill.

Shut off the gas supply when not in use. Always ventilate confined spaces or use approved air-supplied respirator.

HOT PARTS can cause severe burns.

Do not touch hot parts with bare hands.

Allow cooling period before working on gun or torch.

To handle hot parts, use proper tools and/or wear heavy, insulated welding gloves and clothing to prevent burns.

MAGNETIC FIELDS can affect pacemakers.

Pacemaker wearers keep away.

Wearers should consult their doctor before going near arc welding, gouging, or spot welding operations.

NOISE can damage hearing.

Noise from some processes or equipment can damage hearing.

Wear approved ear protection if noise level is high.

Shielding gas cylinders contain gas under high pressure.

CYLINDERS can explode if damaged.

Protect compressed gas cylinders from excessive heat, mechanical shocks, physical damage, slag, open flames, sparks, and arcs. Install cylinders in an upright position by securing to a stationary support or cylinder rack to prevent falling or tipping. Keep cylinders away from any welding or other electrical circuits. Never drape a cutting torch over a gas cylinder. Never allow a cutting tip to touch any cylinder. Never cut a pressurized cylinder - explosion will result. Use only correct shielding gas cylinders, regulators, hoses, and fittings designed for the specific application; maintain them and associated parts in good condition.

Turn face away from valve outlet when opening cylinder valve.

Use the right equipment, correct procedures, and sufficient number of persons to lift and move cylinders.

Read and follow instructions on compressed gas cylinders, associated equipment, and Compressed Gas Association (CGA) recommendations.

2.0 Product Description

This welding machine is manufactured using advanced inverter technology. The input voltage is rectified to DC and then inverted to high frequency AC voltage. Before being converted back to DC for the output. This allows the use of a much smaller transformer and so allowing weight saving and improved power efficiency.

3.0 Technical Specifications

	XTP-40	
	110V Input	230V Input
Input voltage	110V +/- 10%	230V +/- 10%
Frequency	50/60Hz	50/60Hz
Input current	32A MAX	24A MAX
Fuse rating	32A (D rating)	16A (D rating)
Output OCV	480V	480V
Output load voltage	88-92V	88-96V
Output Current	20-30A DC	20-40A DC
Cutting capacity Production	10mm	15mm
Cutting Capacity Severance	15mm	20mm

4.0 Description of Controls

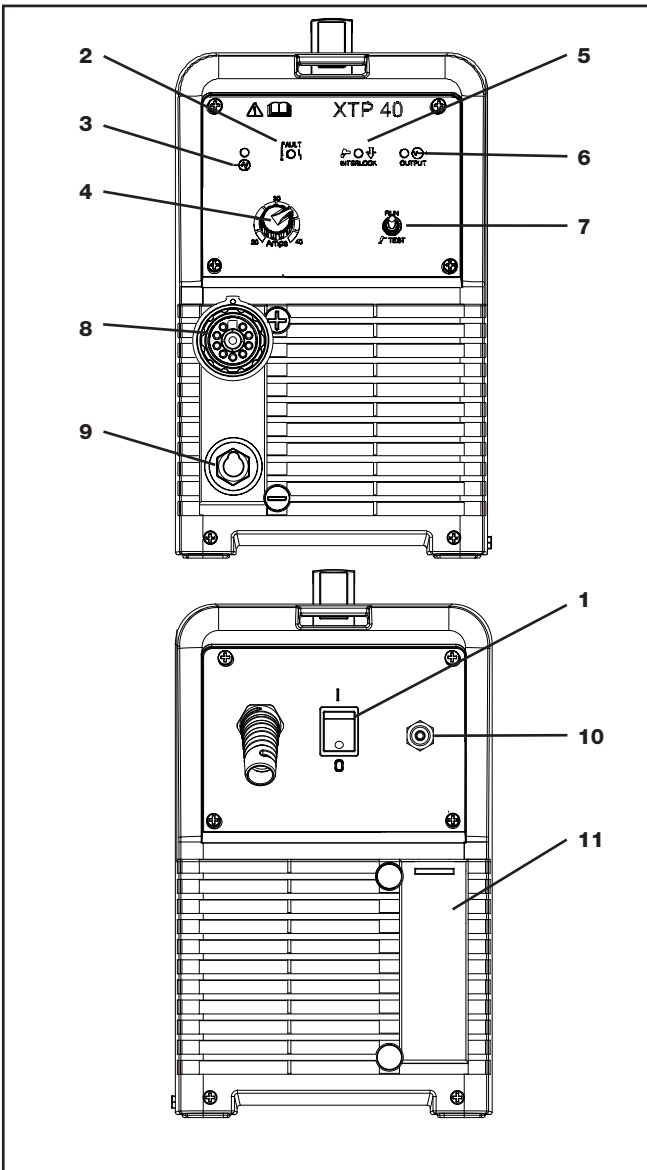

- 1) ON OFF Switch for switching on or off the mains supply to the machine. The switch is mounted on the rear panel.
- 2) Fault light This indicates a fault or over temperature condition with the machine refer to the fault finding section for further information
- 3) Power light This indicates mains power is applied to the machine and that the machine is currently switched on when the light is illuminated
- 4) Output power control for adjustment of the power output of the machine between 20 and 40Amps.
- 5) Interlock fault. If this light illuminates it indicates one of the following. Short circuit between the electrode and tip, front end torch parts missing or incorrectly fitted, Shield cup not fitted correctly (lamp flashes) low air pressure.
- 6) Output power on. Illuminates when the DC output current is on.
- 7) Run/Set switch. In the set position the Air can be checked by pressing the trigger to ensure the air is connected and flowing.

- 8) Torch connector
- 9) Earth lead connector.
- 10) Air line connector
- 11) Consumable holder

5.0 Installation

Read entire installation section before starting installation.

SAFETY PRECAUTIONS

- **ELECTRIC SHOCK** can kill.
- Only qualified personnel should perform this installation.
- Only personnel that have read and understood the Operating Manual should install and operate this equipment.
- Machine must be grounded per any national, local or other applicable electrical regulations.
- The power switch is to be in the OFF position when installing work cable and torch and when connecting other equipment.

5.1 Unpacking the Machine

Carefully remove the machine from the packaging, we recommend you retain the packaging until the machine has been fully installed and tested incase it has been damaged in transit and has to be returned to the re-seller.

5.2 Location

Be sure to locate the welder according to the following guidelines:

In areas, free from moisture and dust.

Ambient temperature between 0-40°C.

In areas, free from oil, steam and corrosive gases.

In areas, not subjected to abnormal vibration or shock.

In areas not exposed to direct sunlight or rain.

Place at a distance of 12" (300 mm) or more from walls or similar that could restrict natural airflow for cooling.

5.3 Input and grounding connection

WARNING

Before starting the installation, check that your power supply is adequate for the voltage, amperage, phase, and frequency specified on the Machine nameplate.

Operate the welding power source from a single-phase 50/60 Hz, AC power supply. The input voltage must match one of the electrical input voltages shown on the input data label on the unit nameplate. The XTP-40 machine can be used on 230V or 110V supply and will automatically adjust itself depending upon the voltage applied.

Refer to the specifications table for voltage tolerances.

Have a qualified electrician connect the input plug. For long runs over 30m , larger copper wires should be used. The green/yellow wire in the input cable connects to the frame of the machine. This ensures proper grounding of the machine when the machine plug is inserted into the receptacle.

5.4 Torch installation

Connect the torch to the machine using the special tool supplied as illustrated below.

- 1) Insert the tool into the hole on the outside of the locking ring and apply pressure to release the locking ring

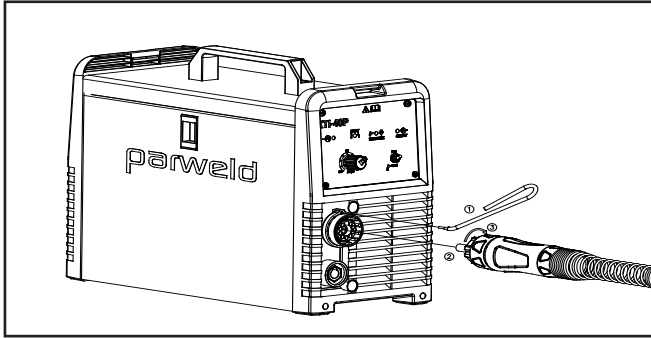

- 2) Push the torch connector into the socket on the machine taking care to line up the pins.
- 3) Tighten the hand nut on the torch to secure the torch
- 4) Release pressure on the locking tool and remove

CAUTION: Before switching on the machine ensure all spares are fitted correctly to the torch and in good condition failure fit spare parts can result in the destruction of the torch head.

5.6 Work return lead connection

Insert the connector in the socket and twist clockwise to lock.

6.0 Operation

WARNING

When using an open arc process, it is necessary to use correct eye, head, and body protection.

6.1 Consumable parts

The electrode, swirl ring and cutting tip are held in position by the nozzle; removal of the nozzle allows these parts to be replaced. Cutting tip size should be selected to match the selected amperage on the machine and is not related to the thickness of the material to be cut. Electrodes should be replaced when the insert has eroded to a depth of no more than 1.2mm failure to replace the electrode may result in permanent torch damage. The life of the electrode is dependant upon the cut amperage and the number of starting operations performed. The higher start frequency and cutting power will give the shortest electrode life. Check the electrode condition every 30 minutes of cutting

6.2 Switching on the machine

When the machine is switched on it will perform a self test routing as detailed following.

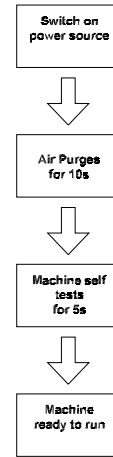

6.3 Setting the Air pressure

Connect the air line to the rear of the machine and Switch on the machine. The air supply should be capable of supplying compressed air at a pressure of 5Bar and a flow rate of 155lpm free air delivery. Switch on the machine and set the toggles switch on the front panel to SET so that air flows through the torch. With the air flowing ensure the interlock light does not come on, if the interlock light illuminates then the air supply pressure to the machine must be increased.

6.4 Getting ready to cut

Use the control knob on the front of the machine to adjust the require output current, a higher current will give faster cutting and a lower current slower cutting but more control for detail cutting. The higher the set current the greater the wear rate will be for the tip and electrode.

6.5 Cut Quality

Cut quality requirements differ depending on application. Bevel angle may be a major factor when the surface will be welded after cutting. Dross-free cutting is important when finish cut quality is desired to avoid a secondary cleaning operation. Rounding on the top edge of a cut due to wearing from the initial contact of the plasma arc on the work piece. Dross is molten material which is not blown out of the cut area and re-solidifies on the plate. Top spatter is dross which accumulates on the top surface of the work piece. Excessive dross may require secondary clean-up operations after cutting. Improper standoff (the distance between the torch tip and work piece) can adversely affect tip life as well as shield cup life. Standoff may also significantly affect the bevel angle. Reducing standoff generally results in a squarer cut. A guide clip and crown stand off guide is available to maintain a constant stand off height. The plasma gas stream swirls as it leaves the torch. The purpose of the swirl is to maintain a smooth column of gas. The swirl effect results in one side of a cut being squarer than the other. Viewed along the direction of travel, the right side of the cut is squarer than the left. If dross is present on carbon steel, it is commonly referred to as either "high speed, slow speed, or top dross". Dross present on top of the plate is normally caused by too great a torch to plate distance. Top dross is normally very easy to remove and can often be wiped off with a welding glove. Slow speed dross is normally present on the bottom edge of the plate. It can vary from a light to heavy bead, but does not adhere tightly to the cut edge, and can be easily scraped off. High speed dross usually forms a narrow bead along the bottom of the cut edge and is very difficult to remove. When cutting troublesome steel, it is sometimes useful to reduce the cutting speed to produce slow speed dross. Any resultant cleanup can be accomplished by scraping, not grinding. Starting the Cut Edge Starting For edge starts, hold the torch perpendicular to the work piece with the front of the tip on the edge of the work piece at the point where the cut is to start. When starting at the edge of the plate, do not pause at the edge and force the arc to "reach" for the edge of the metal. Establish the cutting arc as quickly as possible.

6.6 Piercing

For piercing, angle the torch slightly too direct sparks away from the torch until the pierce is complete. Start and complete the pierce close to the cutting line and then continue the cut onto the line. Hold the torch perpendicular to the work piece after the pierce is complete. Clean spatter and scale from the outer nozzle and the tip as soon as possible. A light coating of anti-spatter compound may be applied to the outside to minimize the amount of scale which adheres to it. Be careful not to get anti-spatter compound on the torch tip or other parts.

6.7 Operating the torch

With the torch in starting position press and hold the trigger. After an initial gas purge, the main arc will come on. Once on, the main arc remains on as long as the trigger switch is held down, unless the torch is withdrawn from the work or torch motion is too slow. If the cutting arc is interrupted, the cutting process must be restarted. To shut off the torch simply release the trigger switch. When the switch is released a 15 second post-flow will occur. If the torch switch is closed during the post-flow, the cutting arc will restart after switching off the air. Refer to the flow chart below for the operating sequence.

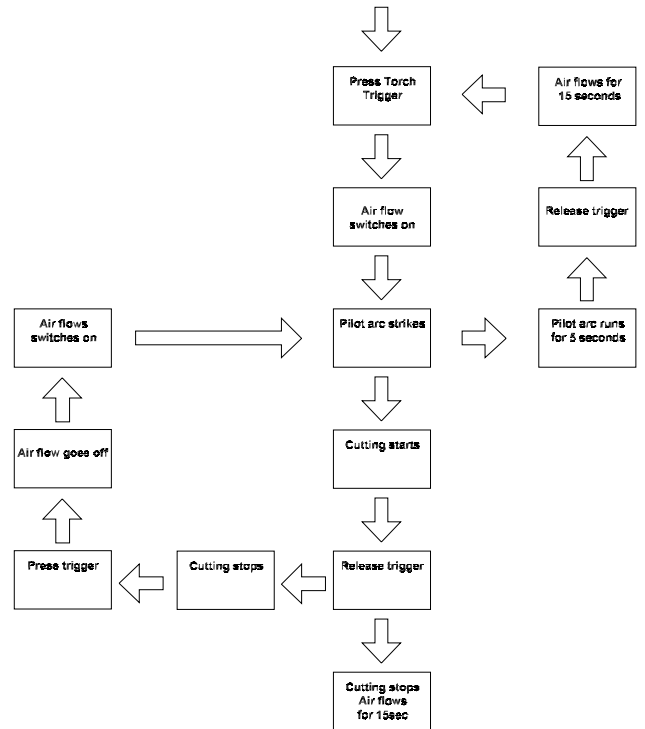

7.0 Fault Finding

Cutting problems

Description	Possible cause	Remedy
Torch cuts but not adequately	1. Current set too low 2. Torch is being moved too fast across work piece 3. Oil or moisture in torch	1. Increase current setting. 2. Reduce cutting speed 3. Ensure water trap on rear of machine is empty (disconnect air supply to allow it to drain). Put machine in setting mode Hold torch 1/8 inch (3 mm) from clean surface while purging and observe oil or moisture buildup (do not activate torch)
Heavy dross on underside of plate	Cutting power is too low	Increase cutting power

Description	Possible cause	Remedy
Cut is not straight	1. Tip is damaged 2. Cut direction is not correct.	Reduce travel speed; ensure correct tip is fitted for amperage. Observe correct standoff and direction of cut

Power source problems

Cut quality is dependent on the selection of the correct consumable, maintenance of equipment and proper cutting technique.

Description	Possible Cause	Remedy
Interlock light illuminates when trigger pressed	Air pressure is set to low	Adjust air pressure to 5Bar. Restart the power source
Interlock light flashes when trigger pressed	Outer nozzle or other consumable not installed correctly	re-assemble front end spares to ensure outer nozzle is seated fully. Restart the power source
Interlock light illuminates when trigger pressed, and the air flow is intermittent	Cutting tip or electrode not installed correctly Short circuit in side the torch or cable	re-install the tip and electrode. Restart the power source Have it checked by a qualified engineer
Fault light illuminates	Machine has over heated. Input voltage is to high Internal machine fault	Allow machine to cool with fan running Ensure input voltage is correct Have machine inspected by qualified engineer
Torch does not start when trigger pressed	Machine is in Set mode	Change switch to run mode on front panel

ROUTINE MAINTENANCE

The only routine maintenance required for the power supply is a thorough cleaning and inspection, with the frequency depending on the usage and the operating environment.

Warning

Disconnect primary power at the source before removing the cover. Wait at least two minutes before opening the cover to allow the primary capacitors to discharge.

To clean the unit, remove the screws securing the outer cover, lift off the outer cover and use a vacuum cleaner to remove any accumulated dirt and dust. The unit should also be wiped clean, if necessary; with solvents that are recommended for cleaning electrical apparatus.

8.0 Accessories

Parweld XT4000

Rating: 60A @ 80% Duty Cycle, EN60974-7

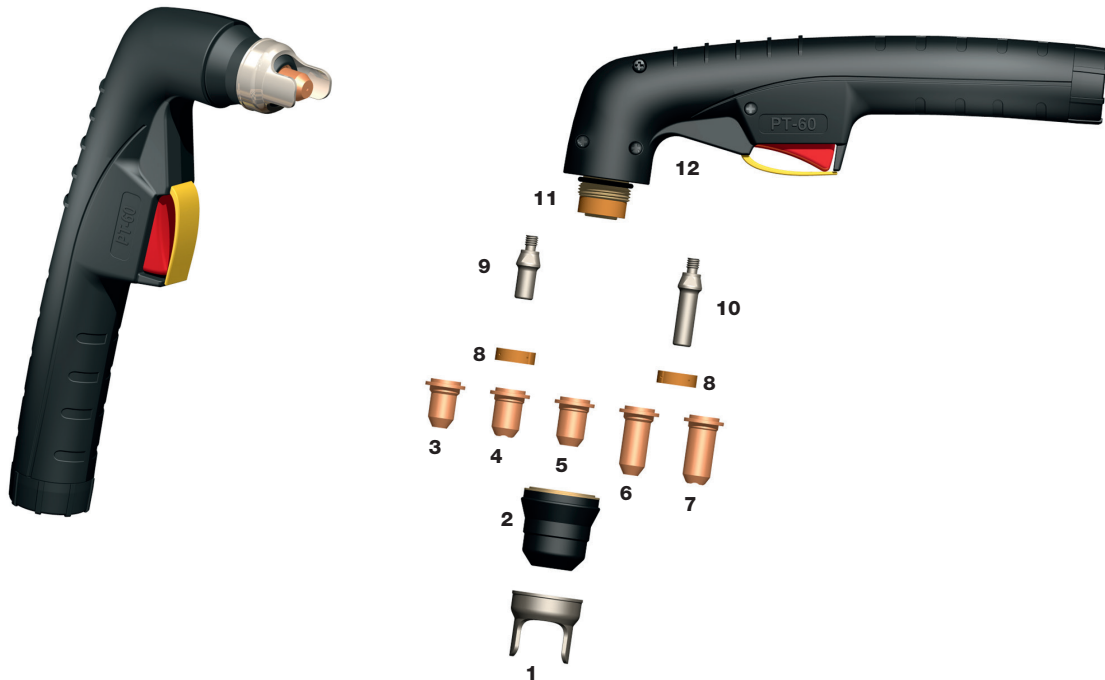

Technical Data

Voltage Class	M
Standard Length	6mt
Air Consumption	110 l/min
Air Pressure	5 Bar
Duty Cycle 80%	60A
Start Method	Non HF with Pilot Arc

Torch Model

Stock Code	Description
XT4000	Plasma Torch x 6mt Central Connector

Consumables

Stock Code	Description
1 XT4008	Double Pointed Spacer
2 XT4007	Retaining Cap
3 XT4005-08	Cutting Tip 0.8mm 20-30A
4 XT4005-09	Cutting Tip 0.9mm 30-40A
5 XT4005-10F	Flat Cutting Tip 1.0mm 40-50A
XT4005-11F	Flat Cutting Tip 1.1mm 50-60A
6 XT4005-08L	Extended Cutting Tip 0.8mm 20-30A
7 XT4005-09L	Extended Cutting Tip 0.9mm 30-40A
8 XT4006	Gas Distributor
9 XT4003	Electrode
10 XT4003L	Extended Electrode
11 XT4010	O Ring
12 XT4001	Torch Head

9.0 EC declaration of conformity

Hereby we declare that the machines as stated below

Type: XTP-40

Conform to the EC Directives:
Low Voltage Directive 2006/95/EC
EMC Directive 2004/108/EC

Harmonised European standard: EN/IEC 60974-1

This is to certify that the tested sample is in conformity with all provisions of the above detailed EU directives and product standards.

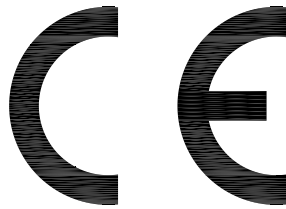

9.1 Rohs Compliance Declaration

Directive 2011/65/EU of the European Parliament
Restriction of use of certain hazardous substances in electrical and electronic equipment

Type: XTP-40

The above listed products are certified to be compliant with the rohs directive with all homogeneous component parts being controlled to ensure material contents as per the list below.

Cadmium 0.01% by weight
Lead 0.1% by weight
Mercury 0.1% by weight
Hexavalent chromium 0.1% by weight
Polybrominated biphenyl's (pbbs) 0.1% by weight
Polybrominated diphenyl ethers (pbdes) 0.1% by weight

It should be noted that under specific exempted applications, where lead is used as an alloying element the following limits are applied in accordance with the regulations.

Copper and copper alloy parts use less than 4% by weight of each homogeneous component.

Steel and steel alloy parts use less than 4% by weight of each homogeneous component.

Aluminium and aluminium alloy parts use less than 4% by weight of each homogeneous component.

Only dispose off in authorised sites for electrical and electronic waste do not dispose of with general refuse or landfill waste.

9.2 WEEE Statement

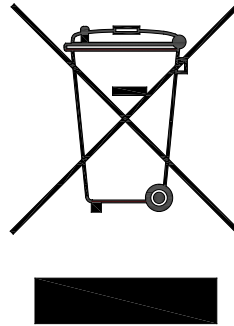

WEEE (Waste Electrical & Electronic Equipment) 2002/96/EC

In relation to implementing the legislation, Parweld has established relevant recycling and recovery methods. We have been fully compliant against the marking requirements since August 2005. Parweld is registered in the UK with the Environment agency as detailed below. For WEE compliance outside the UK please contact your supplier/Importer

Parweld is registered with a compliance scheme Official registration number is WEE/FD0255QV

When your equipment reaches the end of its service life you should return it to Parweld where it will be reconditioned or processed for recycling.

9.3 Statement of warranty

Limited Warranty:

Parweld Ltd, hereafter, "Parweld" warrants its customers that its products will be free of defects in workmanship or material. Should any failure to conform to this warranty appear within the time period applicable to the Parweld products as stated below, Parweld shall, upon notification thereof and substantiation that the product has been stored, installed, operated, and maintained in accordance with Parweld's specifications, instructions, recommendations and recognized standard industry practice, and not subject to misuse, repair, neglect, alteration, or accident, correct such defects by suitable repair or replacement, at Parweld's sole option, of any components or parts of the product determined by Parweld to be defective.

Parweld makes no other warranty, express or implied. This warranty is exclusive and in lieu of all others, including, but not limited to any warranty of merchantability or fitness for any particular purpose.

Limitation of Liability:

Parweld shall not under any circumstances be liable for special, indirect or consequential damages, such as, but not limited to, lost profits and business interruption. The remedies of the purchaser set forth herein are exclusive and the liability of Parweld with respect to any contract, or anything done in connection therewith such as the performance or breach thereof, or from the manufacture, sale, delivery, resale, or use of any goods covered by or furnished by Parweld whether arising out of contract, negligence, strict tort, or under any warranty, or otherwise, shall not, except as expressly provided herein, exceed the price of the goods upon which such liability is based. No employee, agent, or representative of Parweld is authorized to change this warranty in any way or grant any other warranty.

Purchaser's rights under this warranty are void if replacement parts or accessories are used which in Parweld's sole judgement may impair the safety or performance of any Parweld product.

Purchaser's rights under this warranty are void if the product is sold to purchaser by non-authorized persons.

The warranty is effective for the time stated below beginning on the date that the authorized Distributor delivers the products to the purchaser. Notwithstanding the foregoing, in no event shall the warranty period extend more than the time stated plus one year from the date Parweld delivered the product to the authorized distributor.

Parweld Limited
Bewdley Business Park
Long Bank
Bewdley
Worcestershire
England
DY12 2TZ

tel. +44 1299 266800
fax. +44 1299 266900

www.parweld.com
info@parweld.co.uk